

DESCRIPTION

FOREDE Series FRD004/FRD005 11.2K Standard Response, Standard Coverage Upright and Pendent Sprinklers are automatic sprinklers of the frangible bulb type. They are standard response, spray sprinklers that produce a hemispherical water distribution pattern below the deflector.

The 11.2 K-factor, FRD004/FRD005 Sprinklers were subjected to full-scale, high-piled storage fire tests to qualify their use in lieu of 5.6 or 8.0 K-factor standard spray sprinklers for the protection of high-piled storage.

Higher flow rates can be achieved at much lower pressures with the 11.2 K-factor, FRD004/FRD005 Sprinklers, making their use highly advantageous in high density applications, such as the protection of high-piled storage.

Chrome coatings can be used to extend the life of the brass components used in Series FRD004/FRD005 Sprinklers beyond that which would otherwise be obtained when exposed to corrosive atmospheres. Although coated sprinklers have passed the standard corrosion tests of the applicable approval agencies, the testing is not representative of all possible corrosive atmospheres. Consequently, it is recommended that the end-user be consulted with respect to the suitability of these corrosion resistant coatings for any given corrosive environment. The effects of ambient temperature, concentration of chemicals, and gas/chemical velocity, should be considered, as a minimum, along with the corrosive nature of the chemical to which the sprinklers will be exposed.

NOTICE

The 11.2 K-factor, Series FRD004/FRD005 Upright and Pendent Sprinklers described herein must be installed and maintained in compliance with this document, as well as with the applicable standards of local , in addition to the standards of any other authorities having jurisdiction. Failure to do so may impair the performance of these devices.

The owner is responsible for maintaining their fire protection system and devices in proper operating condition. Contact the installing contractor or product manufacturer with any questions.

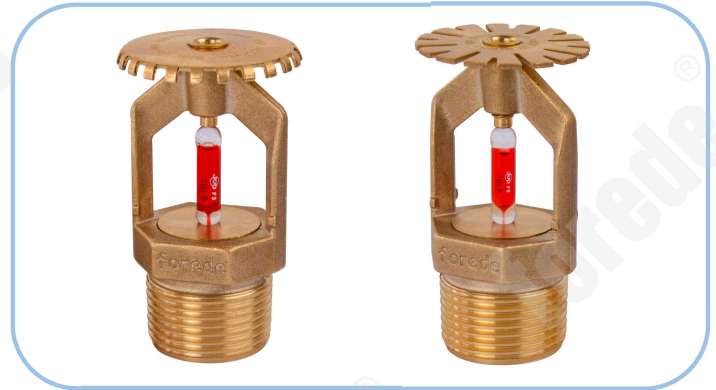

TECHNICAL DATA

Physical Characteristics

- FrameBrass
- CapBrass
- Sealing Assembly Glass bulb 5mm.Glass
- Compression ScrewBrass
- DeflectorBrass

Refer to TABLE A & TABLE B for additional technical data.

Sprinkler Finishes

Refer to TABLE C

Approvals

ISO9001 & CCC

<u>TABLE A</u>	
MODEL	FRD004
WORKING PRESSURE	175 psi (12,1 bar)
CONNECTION	3/4" BSP (NPT OPTIONAL)
K-FACTOR	11.2 GPM/psi ^{1/2} (161,4 LPM/bar ^{1/2})
TEMPERATURE RATING	155 °F (68 °C) 200 °F (93 °C) 286 °F (141 °C)
INSTALLATION	Upright

<u>TABLE B</u>	
MODEL	FRD005
WORKING PRESSURE	175 psi (12,1 bar)
CONNECTION	3/4" BSP (NPT OPTIONAL)
K-FACTOR	11.2 GPM/psi ^{1/2} (161,4 LPM/bar ^{1/2})
TEMPERATURE RATING	155 °F (68 °C) 200 °F (93 °C) 286 °F (141 °C)
INSTALLATION	Pendent

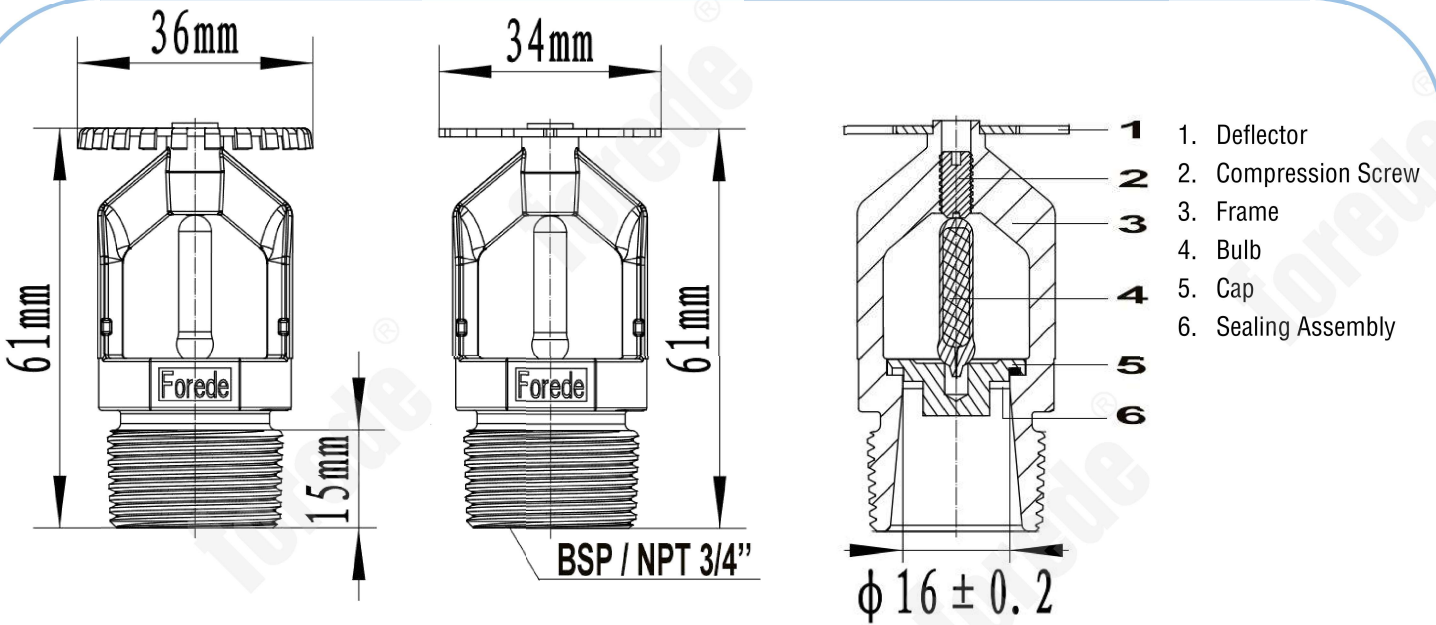

**FRD004/FRD005, 11.2 K-factor, 3/4 Inch
Upright and Pendent Sprinklers
Standard Response, Standard Coverage**

TABLE C

SPRINKLER TYPE	TEMPERATURE RATING	GLASS BULB LIQUID COLOR	SPRINKLER FINISH		
			NATURAL BRASS	CHROME PLATING	BRASS THREAD +CHROME FRAME
UPRIGHT - FRD004	155 °F (68 °C)	Red	-Three finish versions optional for sprinkler -Corrosion resistance for sprinkler -Sandblasting available for sprinkler		
	200 °F (93 °C)	Green			
	286 °F (141 °C)	Blue			
PENDENT - FRD005	155 °F (68 °C)	Red			
	200 °F (93 °C)	Green			
	286 °F (141 °C)	Blue			

**Glass Bulb & Finish Overview
FRD004/FRD005, 11.2 K-factor, 3/4 Inch, Upright and Pendent Sprinklers
Standard Response, Standard Coverage**

OPERATION

The glass bulb contains a fluid that expands when exposed to heat. When the rated temperature is reached, the fluid expands sufficiently to shatter the glass bulb, allowing the sprinkler to activate and water to flow.

APPLICATION

FRD004/FRD005 11.2K can be used as extinguisher in:

- Factories & High cargo Warehouses
- Shopping malls & Hotels & Buildings
- Hospital & Library
-etc.

INSTALLATION

FOREDE Series FRD004/FRD005 11.2K Standard Response, Standard Coverage Upright and Pendent Sprinklers must be installed in accordance with this section.

A leak-tight 3/4 in. NPT sprinkler joint should be obtained by applying a minimum-to-maximum torque of 10 to 20 lb-ft (13,4 to 26,8 N·m). A leak-tight 1/2 in. NPT sprinkler joint should be obtained by applying a minimum-to-maximum torque of 7 to 14 lb-ft (9,5 to 19,0 N·m). Higher levels of torque can distort the sprinkler inlet with consequent leakage or impairment of the sprinkler.

Notes: Do not install any bulb type sprinkler if the bulb is cracked or there is a loss of liquid from the bulb. With the sprinkler held horizontally, a small air bubble should be present. The diameter of the air bubble is approximately 1/16 in. (1,6 mm) for the 155° F (68° C) to 3/32 in. (2,4 mm) for the 286° F (141° C) temperature ratings.

Do not attempt to make up for insufficient adjustment in the escutcheon plate by under- or over-tightening the sprinkler. Re-adjust the position of the sprinkler fitting to suit.

The Series FRD004/FRD005 Upright and Pendent Sprinklers must be installed in accordance with the following instructions.

Notes: Pendent sprinklers are to be installed in the pendent position; upright sprinklers are to be installed in the upright position.

Step 1. With pipe thread sealant applied to the pipe threads, handtighten the sprinkler into the sprinkler fitting.

Step 2. Tighten the sprinkler into the sprinkler fitting using only the W-Type 3 Sprinkler Wrench (Ref. Figure 1), except that an 8 in. or 10 in. adjustable wrench is to be used for wax-coated sprinklers. With reference to Figure 1, the W-Type 3 Sprinkler Wrench or the adjustable wrench, as applicable, is to be applied to the wrench flats.

When installing wax-coated sprinklers with the adjustable wrench, additional care needs to be exercised to prevent damage to the wax coating on the sprinkler wrench flats or frame arms and, consequently, exposure of bare metal to the corrosive environment. The jaws of the wrench should be opened sufficiently wide to pass over the wrench flats without damaging the wax coating.

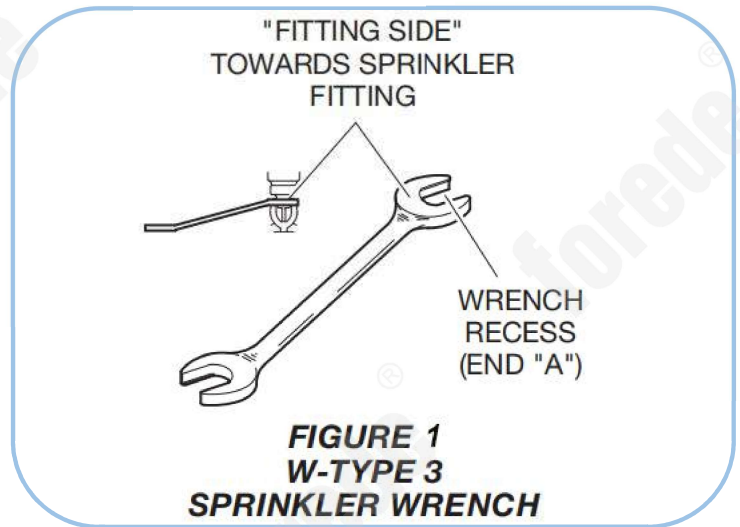

Before wrench tightening the sprinkler, the jaws of the wrench are to be adjusted to just contact the sprinkler wrench flats. After wrench-tightening the sprinkler, loosen the wrench jaws before removing the wrench.

After installation, the sprinkler wrench flats and frame arms must be inspected and the wax coating retouched (repaired) whenever the coating has been damaged and bare metal is exposed. The wax coating on the wrench flats can be retouched by gently applying a heated 1/8 in. diameter steel rod to the areas of wax that have been damaged, to smooth it back over areas where bare metal is exposed.

Notes: Only retouching of the wax coating applied to the wrench flats and frame arms is permitted, and the retouching is to be performed only at the time of the initial sprinkler installation.

The steel rod should be heated only to the point at which it can begin to melt the wax, and appropriate precautions need to be taken, when handling the heated rod, in order to prevent the installer from being burned.

If attempts to retouch the wax coating with complete coverage are unsuccessful, additional wax can be ordered in the form of a wax stick (the end of which is color-coded). Only the correct color-coded wax is to be used, and retouching of wrench flats and frame arms is only permitted at the time of initial sprinkler installation. With the steel rod heated as previously described, touch the rod to the area requiring additional wax with the rod angled downward, and then touch the wax stick to the rod approximately 1/2 in. away from the area requiring retouching. The wax will melt and run down onto the sprinkler.

CARE & MAINTENANCE

FOREDE Series FRD004/FRD005 11.2K Standard Response, Standard Coverage Upright and Pendent Sprinklers must be maintained and serviced in accordance with this section.

Before closing a fire protection system control valve for maintenance work on the fire protection system that it controls, permission to shut down the affected fire protection system must be obtained from the proper authorities and all personnel who may be affected by this action must be notified.

Sprinklers that are found to be leaking or exhibiting visible signs of corrosion must be replaced.

Automatic sprinklers must never be painted, plated, coated or otherwise altered after leaving the factory. Modified sprinklers must be replaced. Sprinklers that have been exposed to corrosive products of combustion, but have not operated, should be replaced if they cannot be completely cleaned by wiping the sprinkler with a cloth or by brushing it with a soft bristle brush.

Care must be exercised to avoid damage to the sprinklers before, during, and after installation. Sprinklers damaged by dropping, striking, wrench twist/slippage, or the like, must be replaced. Also, replace any sprinkler that has a cracked bulb or that has lost liquid from its bulb. For additional information, refer to Installation section.

Frequent visual inspections are recommended to be initially performed for corrosion resistant sprinklers, after the installation has been completed, to verify the long term potential integrity of the sprinkler coatings. Thereafter, annual inspections as standard should suffice; however, instead of inspecting from the floor level, a random sampling of close-up visual inspections should be made, so as to better determine the exact sprinkler condition and the long term integrity of the corrosion resistant coating, as it may be affected by the corrosive conditions present.

The owner is responsible for the inspection, testing, and maintenance of their fire protection system and devices in compliance with this document, as well as with the applicable standards, in addition to the standards of any other authorities having jurisdiction. Contact the installing contractor or product manufacturer with any questions.

ORDERING GUIDE

- Model Number
- Temperature Rating
- Sprinkler Finish (Chrome Plating standard)
- Order Quantity
- Shipping/Transportation Way

Other special requirements please contact FOREDE SALES TEAM.

Tips: for more related products or other firefighting equipment, please forward to our website, www.forede.com

